

Suspension systems

Motorized and safety equipment

PTW aluminum beam available

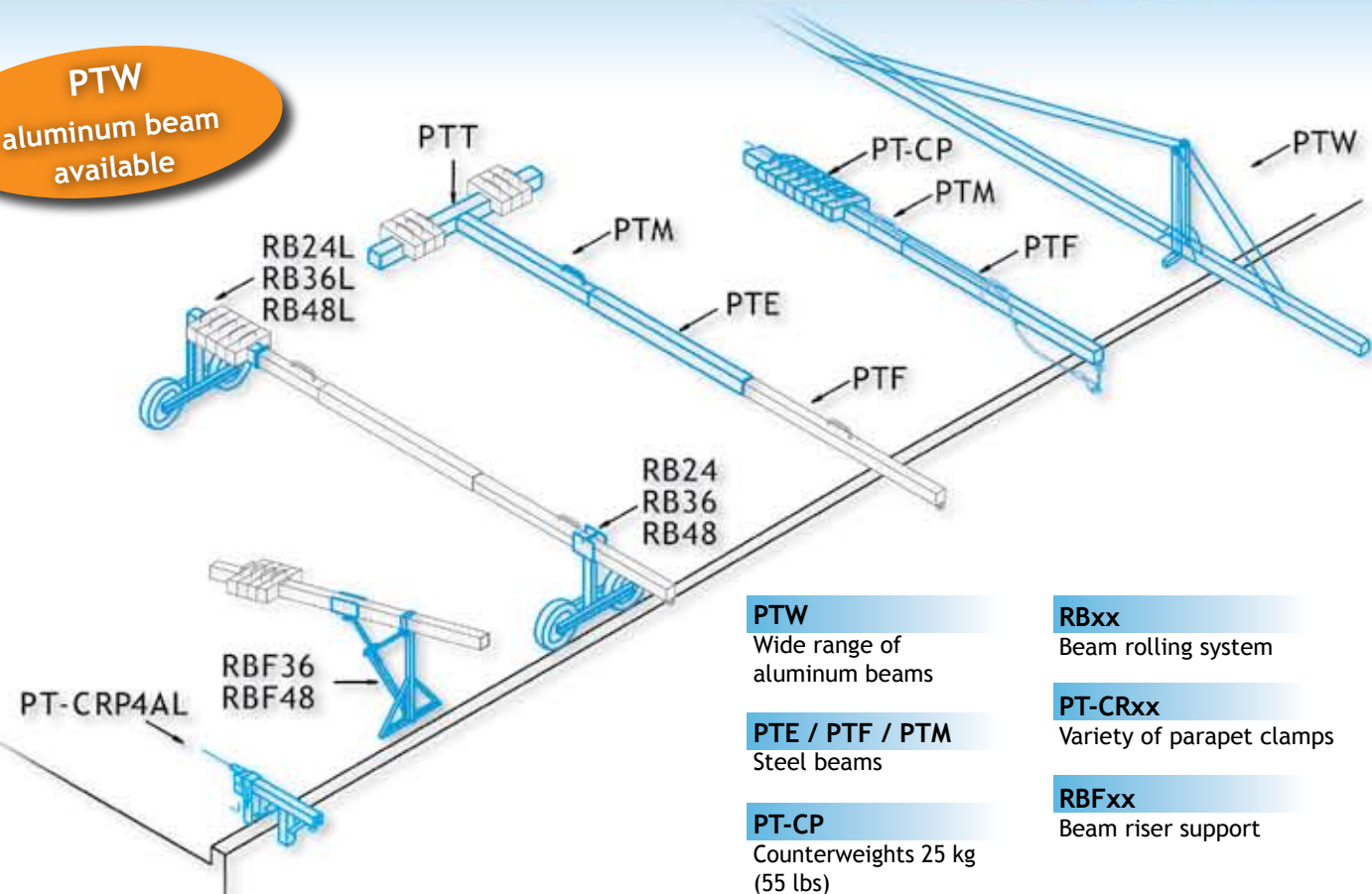

Roll-Around (RR-48)

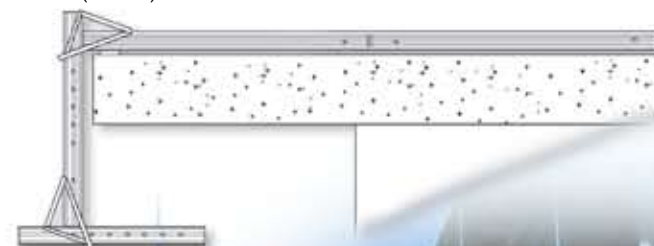
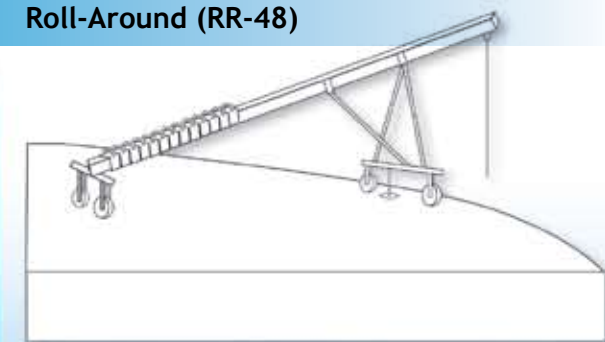

Cantilevered overhang beam



Electric hoists

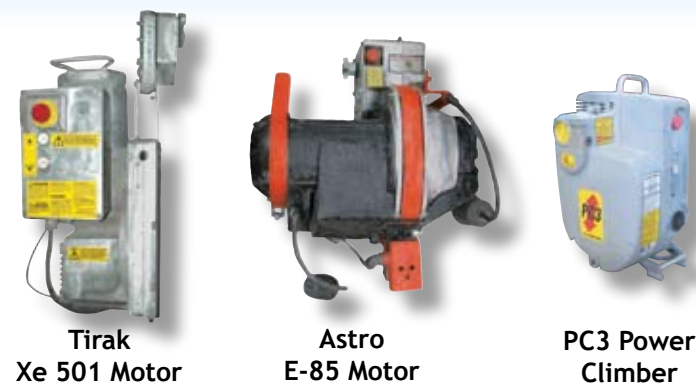

	Tirak XE	Astro E-85	PC3
Load capacity	450 kg (1 000 lbs)	680 kg (1 500 lbs)	350 kg (770 lbs)
Speed	10 m/min. (33' /min.)	10 m/min. (33' /min.)	10 m/min. (33' /min.)
Technical specifications	220V 1 phase 20 Amp.	220V 1 phase 20 Amp.	220V 1 phase 35 Amp.
Weight	50 kg (110 lbs)	54 kg (125 lbs)	N/A

Steel cables

8 mm (5/16") diameter steel cable.
High strength
Note : 9.5 mm (3/8") diameter steel cable also available.



Manual hoists



	TF13	TF7U and TF7
Lifting capacity	1 496 kg (3 300 lbs)	680 kg (1 500 lbs)
Pulling capacity	2 494 kg (5 500 lbs)	
Tested at	2 993 kg (6 600 lbs)	
Handle length	104 cm (41")	73.7 cm (29")
Steel cable	12mm diam (0.47")	9mm diam (0.35")
Overall dimensions	63.5 x 30.5 x 15.2 cm	52.2 x 24.3 x 12.3 cm
Speed	3 m/min. (10' min.)	2-3 m/min. (7'-9' min.)

Personnel safety equipment (for sale only)

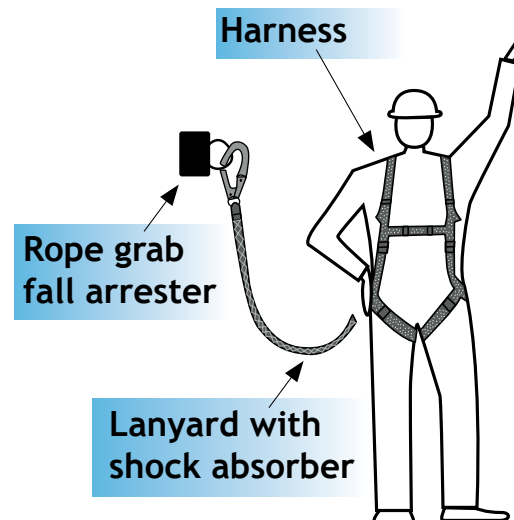

Safety rope
15 mm (5/8") diameter

